



OUR GLOBAL
COMPETENCE
CENTRES

 APOLLO DISPLAY
TECHNOLOGIES



 DISTEC



 DISPLAY
TECHNOLOGY



Datasheet

Amoled

AL101WXL02-N

AM-01-001

The information contained in this document has been carefully researched and is, to the best of our knowledge, accurate. However, we assume no liability for any product failures or damages, immediate or consequential, resulting from the use of the information provided herein. Our products are not intended for use in systems in which failures of product could result in personal injury. All trademarks mentioned herein are property of their respective owners. All specifications are subject to change without notice.



PRODUCT SPECIFICATIONS

- (•) Preliminary specifications
- () Final specifications

DOCUMENT NUMBER: AL101WXL02-N
PRODUCT NO.: AL101WXL02-N
PRODUCT NAME: 10.1" 1280 x 800 LCD Module

CUSTOMER
APPROVED BY
DATE:

APPROVAL



Prepared by	Date	Revision	Changes
SY	Sep. 2, 2015	0.01	Initial release
Asa	Sep. 4, 2015	0.02	Optical modified
Stanley	Oct. 8, 2015	0.03	Add weight

CONFIDENTIAL



Contents

Contents	3
1. Features	4
2. Physical Specifications	4
3. Absolute Maximum Ratings	5
4. Electrical Specifications	6
4.1 Typical Operation Conditions.....	6
4.2 LED Driving Conditions	8
4.3 Power Sequence	9
4.4 LVDS Signal Timing Characteristics	10
4.4.1 AC Electrical Characteristics.....	10
4.4.2 Timing Table.....	11
5. Interface.....	12
6. Optical Specifications.....	14
7. Reliability Test Conditions	17
8. General Precaution	18
9. Outline Dimension	20

CONFIDENTIAL



1. Features

10.1 TFT Liquid Crystal Display module is a color active matrix thin film transistor (TFT) liquid crystal display (LCD) that uses amorphous silicon TFT as a switching device. It is composed of a TFT LCD panel, a timing controller, voltage reference, common voltage, column driver, and row driver circuit. This TFT LCD has a 10.1-inch diagonally measured active display area with 1280 horizontal by 800 vertical pixel array resolution.

2. Physical Specifications

Item	Specifications	Remark
LCD size	10.1 inch(Diagonal)	
Driver element	a-Si TFT active matrix	
Display resolution	1280 (W) × 3(RGB) × 800(H) dots	
Display mode	Normally Black, Transmissive (IPS)	
Dot pitch	0.1695 (W) x0.1695 (H) mm	
Active area	216.96 (W) x 135.6 (H) mm	
Module size	231.0 (W) x 154.4 (H) × 5.7 (D) mm	
Surface treatment	HC	
Color arrangement	R.G.B-stripe	
Interface	Digital	
Weight	240 g	



3. Absolute Maximum Ratings

ITEM	SYMBOL	VALUES		UNIT	REMARK
		MIN	MAX		
Power Voltage	V_{DD}	-0.3	7.0	V	$V_{SS}=0V$, $T_A=25^{\circ}C$
	V_{LED}	-0.3	24	V	
Operation Temperature	T_{op}	-20	70	$^{\circ}C$	
Storage Temperature	T_{st}	-30	80	$^{\circ}C$	

Note : The absolute maximum rating values of this product are not allowed to be exceeded at any times.

Should a module be used with any of the absolute maximum ratings exceeded, the characteristics of the module may not be recovered, or in an extreme case, the module may be permanently destroyed.



4. Electrical Specifications

4.1 Typical Operation Conditions

Item	Symbol	Min	Typ	Max	Unit	Note
LCD Drive Voltage	VDD	3.0	3.3	3.6	V	(2),(4)
VDD Current	White Pattern IDD	--	0.27	--	A	(3),(4)
VDD Power Consumption	White Pattern PDD	--	--	1.0	W	(3),(4)
Rush Current	Irush			1.5	A	(1),(4),(5)
Allowable Logic/LCD Drive Ripple Voltage	VDDrp			300	mV	(4)

Note 1.Measure Condition

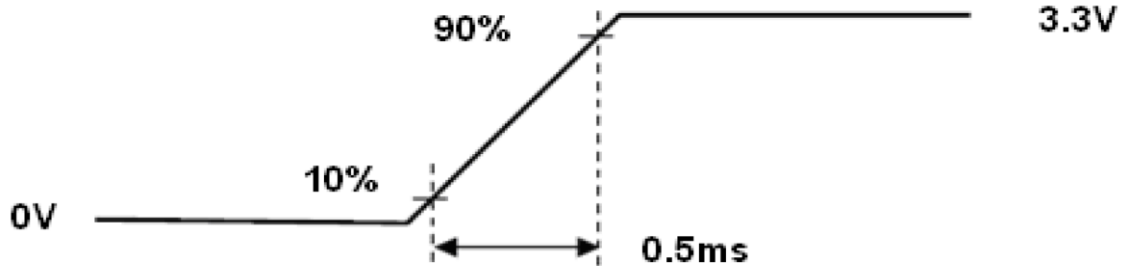

VDD rising time

Note 2.VDD Power Dip Condition

If $V_{TH} < V_{DDRVmin}$, then $t_{dR} < 10ms$; when the voltage return to normal our panel must revive automatically.

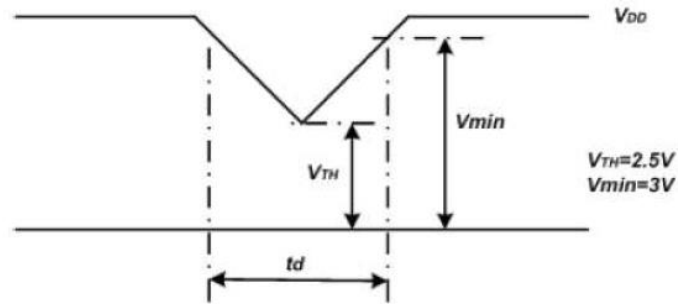

VDD Power Dip

Note (3) Frame Rate=60Hz, VDD=3.3V,DC Current.

Note (4) Operating temperature 25°C , humidity 55%RH.

Note (5) The reference measurement circuit of rush current.

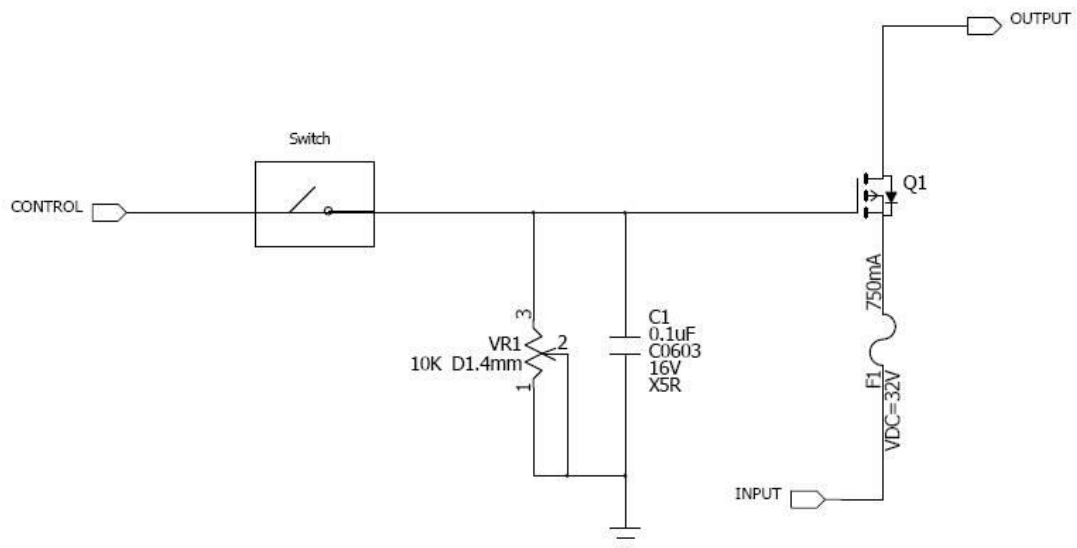



4-2 LED Driving Conditions

ITEM	SYMBOL	MIN	TYP	MAX	UNIT	CONDITION
LED Backlight Voltage	V_{BL}	--	22	24	V	For reference
LED Backlight Current	I_{BL}	-	360	--	mA	Ta=25°C
LED Life Time		--	50K	-	kHr	Note*

Note* : Brightness to be decreased to 50% of the initial value.

Ta=25°C

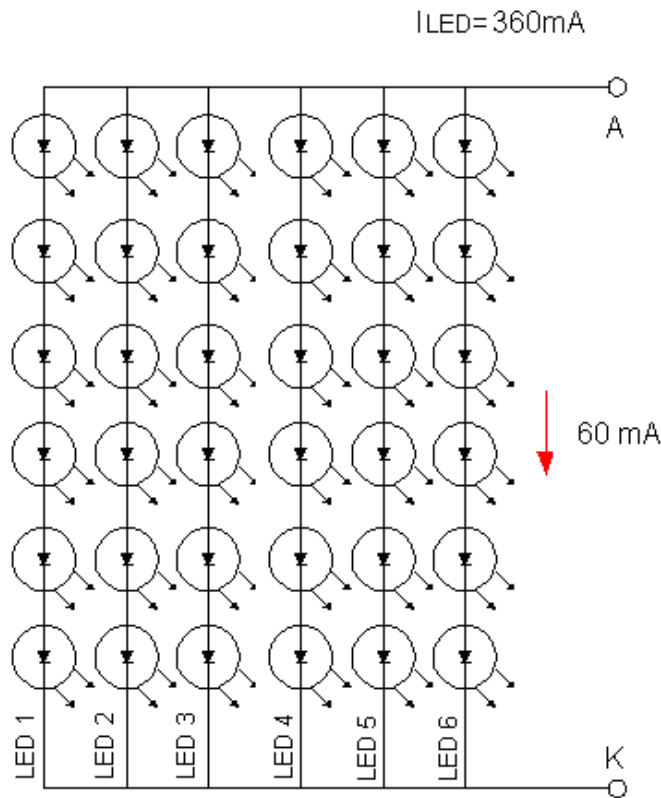

When LCM is operated over 40°C ambient temperature, the ILED should be follow :

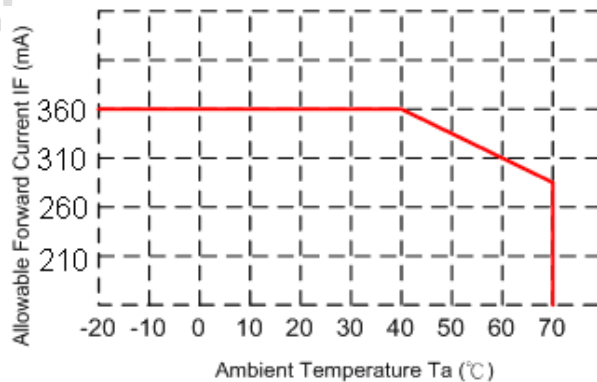



4.3 Power Sequence

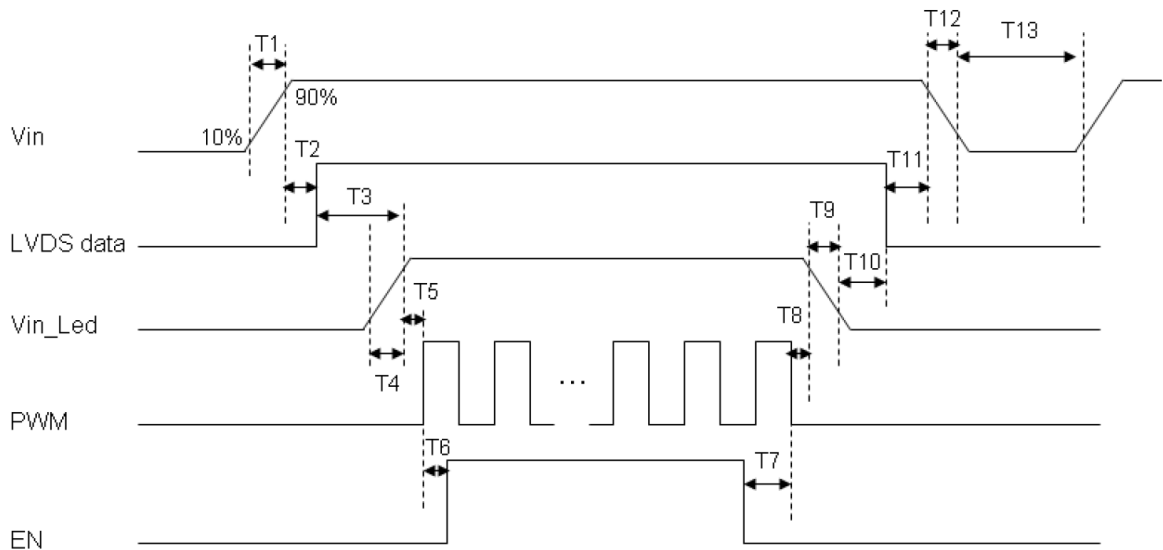

Power Sequencing Requirements

Parameter	Symbol	Unit	Min	Typ.	Max
VIN Rise Time	T1	ms	0.5	--	10
VIN Good to Signal Valid	T2	ms	30	--	90
Signal Valid to Backlight On	T3	ms	200	--	--
Backlight Power On Time	T4	ms	0.5	--	--
Backlight VDD Good to System PWM On	T5	ms	10	--	--
System PWM ON to Backlight Enable ON	T6	ms	10	--	--
Backlight Enable Off to System PWM Off	T7	ms	0	--	--
System PWM Off to B/L Power Disable	T8	ms	10	--	--
Backlight Power Off Time	T9	ms	--	10	30
Backlight Off to Signal Disable	T10	ms	200	--	--
Signal Disable to Power Down	T11	ms	0	--	50
VIN Fall Time	T12	ms	--	10	30
Power Off	T13	ms	500	--	--



4.4 LVDS Signal Timing Characteristics

4.4.1 AC Electrical Characteristics

Parameter	Symbol	Min.	Typ.	Max.	Unit	Conditions
Differential Input High	V _{th}	-	-	+100	mV	V _{CM} =+1.2V
Differential Input Low	V _{tl}	-100	-	-	mV	V _{CM} =+1.2V
Magnitude Differential Input	V _{ID}	200	-	400	mV	-
Common Mode Voltage	V _{CM}	0.3+ (V _{ID} /2)	-	VDD-1.2- (V _{ID} /2)	V	-
Common Mode Voltage	ΔV _{CM}	-	-	50	mV	V _{CM} =+1.2V

Note (1) Input signals shall be low or Hi-Z state when VDD is off.

(2) All electrical characteristics for LVDS signal are defined and shall be measured at the interface connector of LCD.

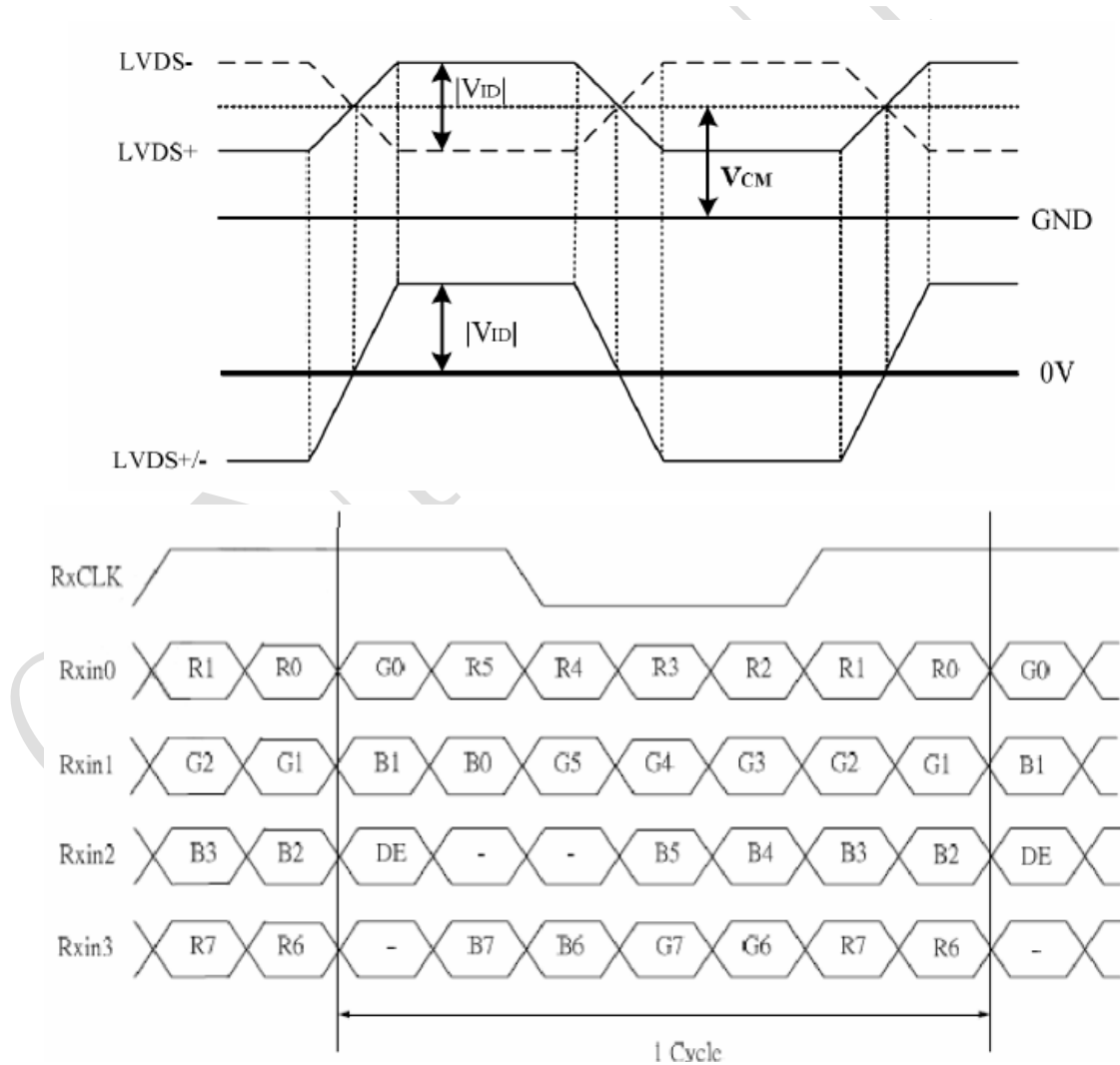



4.4.2 Timing Table

Parameter	Symbol	Unit	Min.	Typ.	Max.
Frame Rate	--	Hz	-	60	-
Frame Period	t_v	line	(815)	(823)	(1023)
Vertical Display Time	t_{VD}	line	800		
Vertical Blanking Time	$t_{VW}+t_{VBP}+t_{VFP}$	line	(15)	(23)	(33)
1 Line Scanning Time	t_H	clock	(1410)	(1440)	(1470)
Horizontal Display Time	t_{HD}	clock	1280		
Horizontal Blanking Time	$t_{HW}+t_{HBP}+t_{HFP}$	clock	(60)	(160)	(190)
Clock Rate	$1/T_C$	MHz	(68.9)	(71.1)	(73.4)

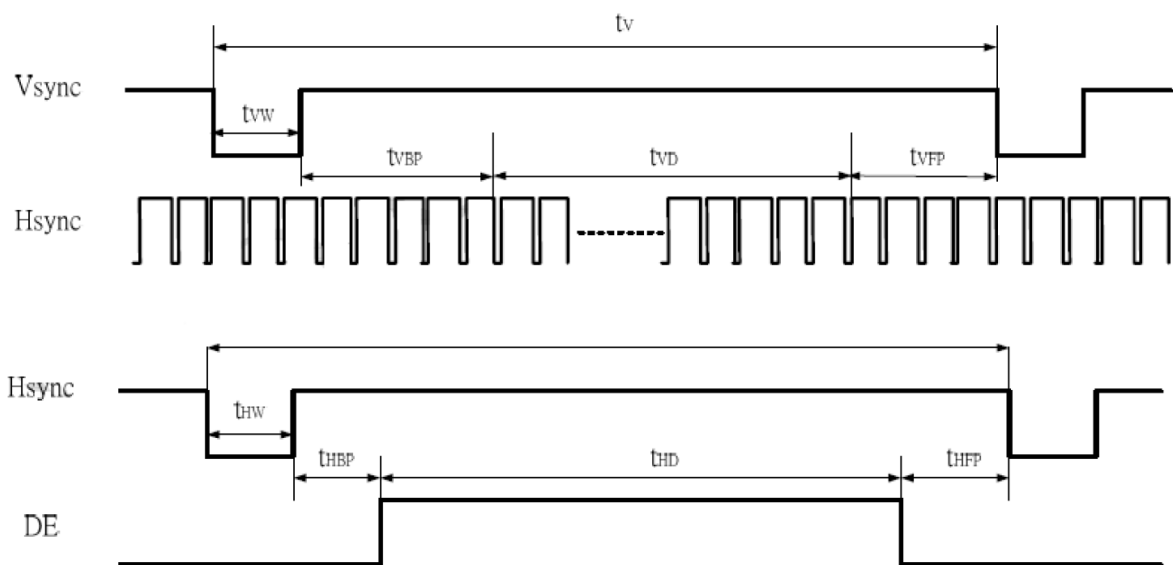



5. Interface

Interface Connector (input signal) : Starconn/300E40-0010RA-G3

Pin #	Signals Name	Description	Remarks
1	NC	Not Connect	-
2	VDD	Power Supply, 3.3V (typical)	-
3	VDD	Power Supply, 3.3V (typical)	
4	VDD_EDID	Power Supply for EDID I2C Flash IC	
5	SCL_EDID	I2C Serial Clock for EDID I2C Flash IC	
6	SDA_EDID	I2C Serial Data for EDID I2C Flash IC	
7	NC	Not Connect	
8	LV0N	-LVDS differential data input	
9	LV0P	+LVDS differential data input	
10	GND	Ground	
11	LV1N	-LVDS differential data input	
12	LV1P	+LVDS differential data input	
13	GND	Ground	
14	LV2N	-LVDS differential data input	
15	LV2P	+LVDS differential data input	
16	GND	Ground	
17	LVCLKN	-LVDS differential data input	
18	LVCLKP	+LVDS differential data input	
19	GND	Ground	
20	LV3N	-LVDS differential data input	
21	LV3P	+LVDS differential data input	
22	GND	Ground	
23	NC	Not Connect	
24	NC	Not Connect	
25	NC	Not Connect	
26	NC	Not Connect	
27	NC	Not Connect	
28	NC	Not Connect	
29	CABC_EN	Content Adaptive Brightness Control Function Enable	Enable: Hi Disable:Lo



30	NC	Not Connect	
31	NC	Not Connect	
32	NC	Not Connect	
33	NC	Not Connect	
34	NC	Not Connect	
35	BIST	BIST pin	
36-40	NC	Not Connect	

CONFIDENTIAL



6. Optical Specifications

Table 2 Optical Characteristics

Item	Conditions		Min.	Typ.	Max.	Unit	Note		
Viewing Angle (CR>10)	Horizontal	θ_L	(75)	(85)	-	degree	(1)		
		θ_R	(75)	(85)	-				
	Vertical	θ_T	(75)	(85)	-				
		θ_B	(75)	(85)	-				
Contrast Ratio	Center		(600)	(800)	-	-	(1),(2)		
Response Time	Rising		-	-	-	ms	(1),(3)		
	Falling		-	-	-	ms			
	Rising + Falling		-	25	-	ms			
Color Chromaticity (CIE1931)	NTSC		-	45	-	%	(1)		
	Red	x	Typ. -0.05	0.561	Typ. +0.05	-	(1)		
	Red	y		0.334		-			
	Green	x		0.341		-			
	Green	y		0.568		-			
	Blue	x		0.161		-			
	Blue	y		0.129		-			
	White	x		-		0.313		-	-
	White	y		-		0.329		-	-
White Luminance	Center			-		1300		-	cd/m ²
Luminance Uniformity	9Points		70	75	-	%	(1),(4)		



Note (1) Measurement Setup:

The LCD module should be stabilized at given temperature(25°C) for 15 minutes to Avoid abrupt temperature change during measuring. In order to stabilize the luminance, the measurement should be executed after lighting backlight for 15 minutes in a windless room.

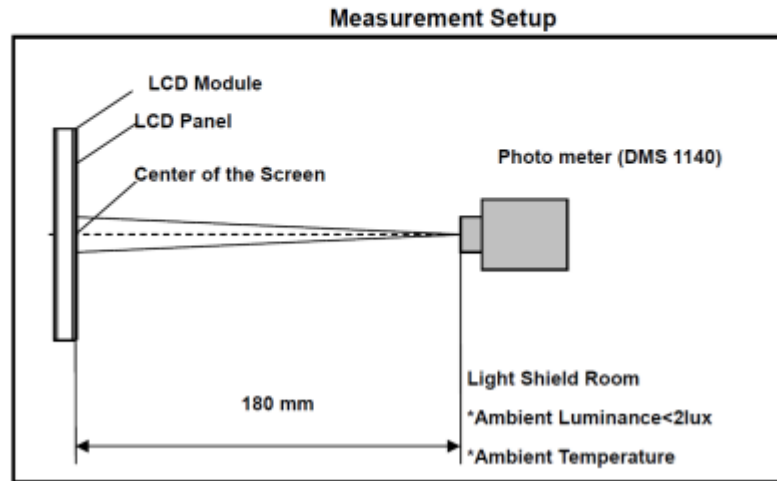

Definition of Viewing Angle

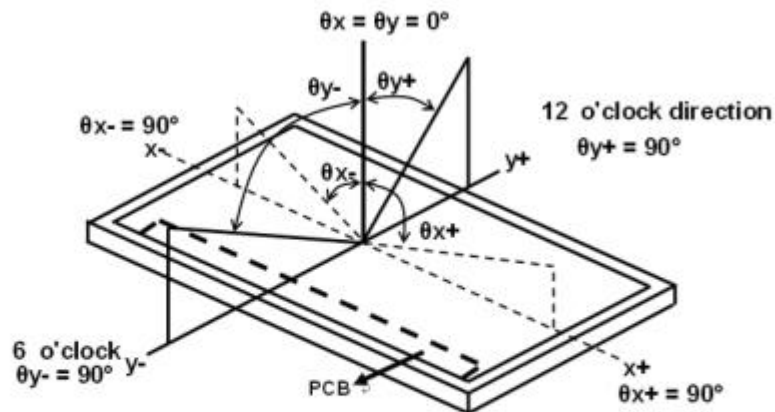

Note (2) Definition Of Contrast Ratio (CR)

The contrast ratio can be calculated by the following expression



Contrast Ratio (CR) = L255 / L0

L63: Luminance of gray level 255, L0: Luminance of gray level 0

Note (3) Definition Of Response Time (T_R, T_F)

Figure 6 Definition of Response Time

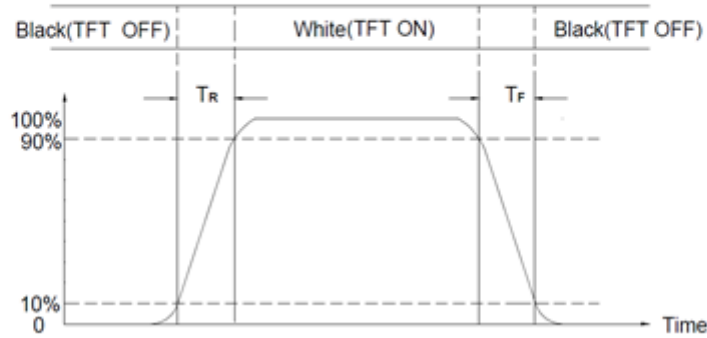

Note (4) Definition Of brightness Luminance

$$\text{Luminance uniformity} = \frac{\text{Min}(L1, L6, L7, L8, L9, L10, L11, L12, L13)}{\text{Max}(L1, L6, L7, L8, L9, L10, L11, L12, L13)} \times 100\%$$

H—Active area length V—Active area width

Measurement Locations

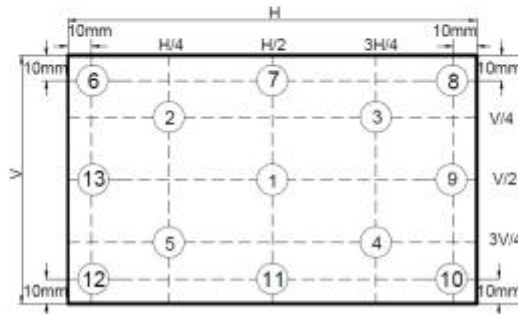



7. Reliability Test Conditions

Test Item	Test Conditions	Note
High Temperature Operation	70±3°C ,Dry t=240 hrs	
Low Temperature Operation	-20±3°C, Dry t=240 hrs	
High Temperature Storage	80±3°C , Dry t=240 hrs	1,2
Low Temperature Storage	-30±3°C ,Dry t=240 hrs	1,2
Thermal Shock Test	-20°C ~ 25°C ~ 70°C 30 m in. 5 min. 30 min. (1 cycle) Total 100 cycle(Dry)	1,2
Storage Humidity Test	60 °C, Humidity 90%, 240 hrs	1,2
Vibration Test (Packing)	Sweep frequency : 10 ~ 55 ~ 10 Hz/1min Amplitude : 0.75mm Test direction : X.Y.Z/3 axis Duration : 30min/each axis	2

Note 1 : Condensation of water is not permitted on the module.

Note 2 : The module should be inspected after 1 hour storage in normal conditions (15-35°C , 45-65%RH).

Definitions of life end point :

- Current drain should be smaller than the specific value.
- Function of the module should be maintained.
- Appearance and display quality should not have degraded noticeably.
- Contrast ratio should be greater than 50% of the initial value.



8. General Precaution

8.1 Use Restriction

This product is not authorized for use in life supporting systems, aircraft navigation control systems, military systems and any other application where performance failure could be life-threatening or otherwise catastrophic.

8.2 Disassembling or Modification

Do not disassemble or modify the module. It may damage sensitive parts inside LCD module, and may cause scratches or dust on the display. AMOLED Corp. does not warrant the module, if customers disassemble or modify the module.

8.3 Breakage of LCD Panel

- (1) If LCD panel is broken and liquid crystal spills out, do not ingest or inhale liquid crystal, and do not contact liquid crystal with skin.
- (2) If liquid crystal contacts mouth or eyes, rinse out with water immediately.
- (3) If liquid crystal contacts skin or cloths, wash it off immediately with alcohol and rinse thoroughly with water.
- (4) Handle carefully with chips of glass that may cause injury, when the glass is broken.

8.4 Electric Shock

- (1) Disconnect power supply before handling LCD module.
- (2) Do not pull or fold the LED cable.
- (3) Do not touch the parts inside LCD modules and the fluorescent LED's connector or cables in order to prevent electric shock.

8.5 Absolute Maximum Ratings and Power Protection Circuit

- (1) Do not exceed the absolute maximum rating values, such as the supply voltage variation, input voltage variation, variation in parts' parameters, environmental temperature, etc., otherwise LCD module may be damaged.
- (2) Please do not leave LCD module in the environment of high humidity and high temperature for a long time.
- (3) It's recommended to employ protection circuit for power supply.

8.6 Operation

- (1) Do not touch, push or rub the polarizer with anything harder than HB pencil lead.
- (2) Use fingerstalls of soft gloves in order to keep clean display quality, when persons handle the LCD module for incoming inspection or assembly.
- (3) When the surface is dusty, please wipe gently with absorbent cotton or other soft material.
- (4) Wipe off saliva or water drops as soon as possible. If saliva or water drops contact with polarizer for a long time, they may cause deformation or color fading.
- (5) When cleaning the adhesives, please use absorbent cotton wetted with a little petroleum benzene or other adequate solvent.

**8.7 Mechanism**

Please mount LCD module by using mounting holes arranged in four corners tightly.

8.8 Static Electricity

- (1) Protection film must remove very slowly from the surface of LCD module to prevent from electrostatic occurrence.
- (2) Because LCD modules use CMOS-IC on circuit board and TFT-LCD panel, it is very weak to electrostatic discharge. Please be careful with electrostatic discharge. Persons who handle the module should be grounded through adequate methods.

8.9 Strong Light Exposure

The module shall not be exposed under strong light such as direct sunlight. Otherwise, display characteristics may be changed.

8.10 Disposal

When disposing LCD module, obey the local environmental regulations.

8.11 Others

Do not keep the LCD at the same display pattern continually. The residual image will happen and it will damage the LCD. Please use screen saver.

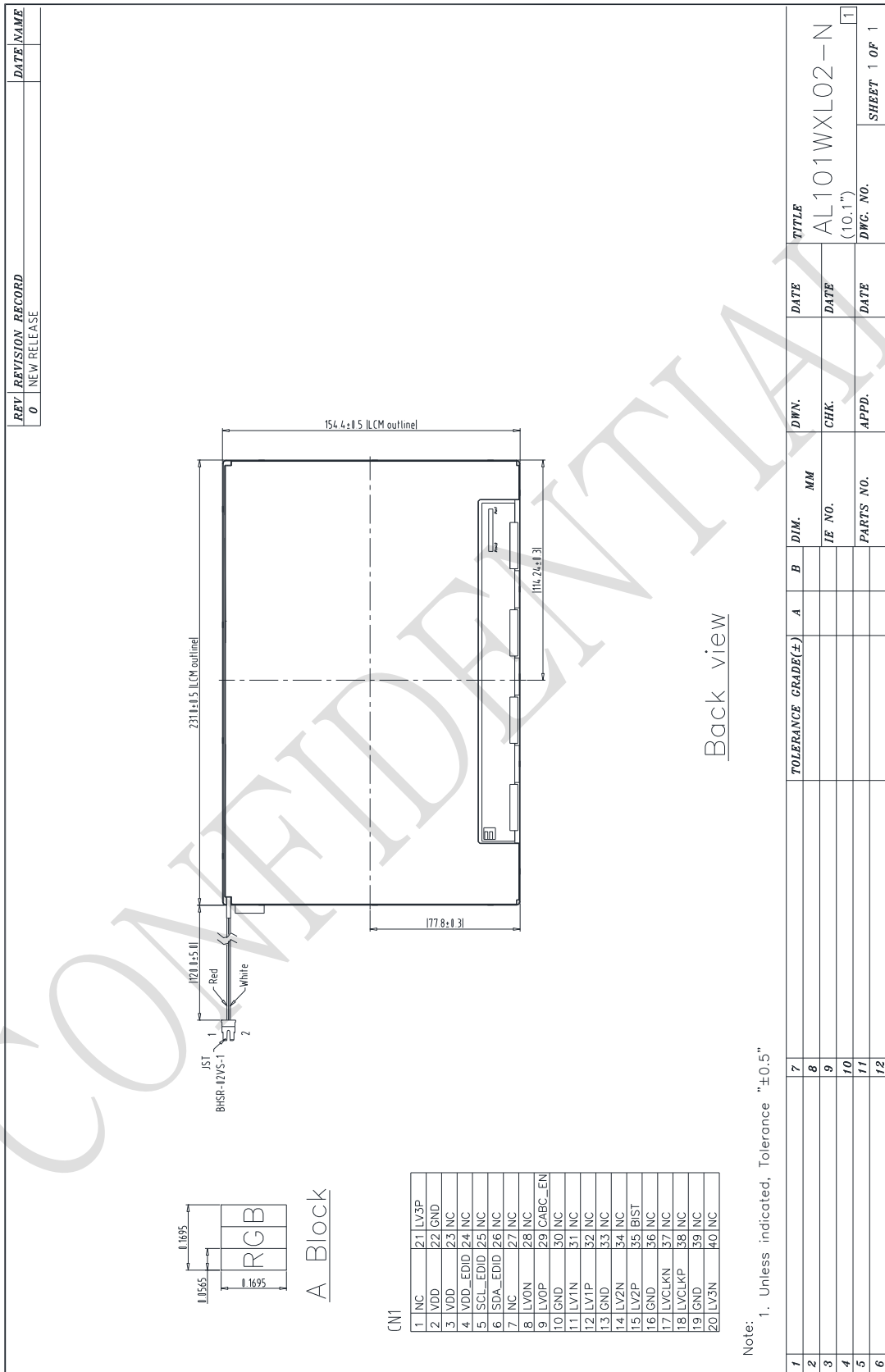

TOLERANCE GRADE(±)	A	B	MM	DWN.	DATE	TITLE
						AL101WXL02-N
				CHK.	DATE	(10.1")
				APPD.	DATE	DWG. NO.
						SHEET 1 OF 1

Our company network supports you worldwide with offices in Germany, Austria, Switzerland, the UK and the USA. For more information please contact:

Headquarters

Germany



FORTEC Elektronik AG
Lechwiesenstr. 9
86899 Landsberg am Lech

Phone: +49 8191 91172-0
E-Mail: sales@forteca.de
Internet: www.forteca.de

Fortec Group Members

Austria



FORTEC Elektronik AG
Office Vienna

Nuschinggasse 12
1230 Wien

Phone: +43 1 8673492-0
E-Mail: office@fortec.at
Internet: www.fortec.at

Germany



Distec GmbH

Augsburger Str. 2b
82110 Germering

Phone: +49 89 894363-0
E-Mail: info@distec.de
Internet: www.distec.de

Switzerland



ALTRAC AG

Bahnhofstraße 3
5436 Würenlos

Phone: +41 44 7446111
E-Mail: info@altrac.ch
Internet: www.altrac.ch

United Kingdom



Display Technology Ltd.

Osprey House, 1 Osprey Court
Hichingbrooke Business Park
Huntingdon, Cambridgeshire, PE29 6FN

Phone: +44 1480 411600
E-Mail: info@displaytechnology.co.uk
Internet: www.displaytechnology.co.uk

USA



Apollo Display Technologies, Corp.

87 Raynor Avenue,
Unit 1 Ronkonkoma,
NY 11779

Phone: +1 631 5804360
E-Mail: info@apolloDisplays.com
Internet: www.apolloDisplays.com